

Heavy Duty Backdraft Damper – Model SH2

Design Features – Airfoil blade heavy-duty backdraft damper designed for use with class I & class II fans.

PLEASE SPECIFY HORIZONTAL OR VERTICAL AIR FLOW

STANDARD CONSTRUCTION

FRAME

8" deep x 2" channel, 12 ga. Galvanized steel

BLADES

18 gauge galvanized, 5" to 6" wide (varies with height dimension)

BLADE AXLES & BEARINGS

AXLE – 1/2" plated steel shaft

BEARINGS – 1/2" Bore ball bearings

LINKAGE

Mounted at the center point of width dimension on face of blades

Dampers over 36" wide will have two sets of linkage

SEAL

Silicone blade & stainless steel jamb seals

COUNTER WEIGHT

Adjustable, on 10 ga galvanized aluminum bracket

MAXIMUM VELOCITY & STATIC PRESSURE

60" wide 4000 FPM @ 8" static pressure

48" wide 4000 FPM @ 9" static pressure

36" wide 4000 FPM @ 10" static pressure

24" wide 4000 FPM @ 12" static pressure

12" wide 4000 FPM @ 15" static pressure

MAXIMUM TEMPERATURE

250° F

MAXIMUM SINGLE SECTION

60"W x 96"H

MINIMUM SIZE

6"W x 8"H

UNDERSIZED

Dampers are sized on ACTUAL INSIDE DIMENSIONS

FINISH

Mill

OPERATOR

None

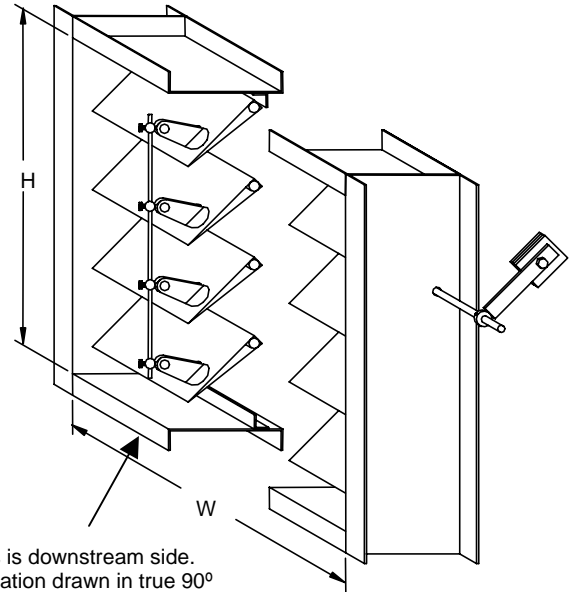

OPTIONAL CONSTRUCTION

FRAME – Available in stainless steel or aluminum up to 10 ga.

BLADES - Available in stainless steel or aluminum up to 14 ga. up to 8" wide

SPECIFIED MATERIAL – Available in stainless steel, aluminum or as requested

SEALS – Neoprene foam or polyurethane foam blade edge

LINKAGE – Concealed in jamb

FINISH – Air-dry primer, polyurethane, epoxy, or enamel, baked epoxy or enamel, Kynar, or Powder coat. For industrial special purpose coating, please consult factory.

SPECIAL PURPOSE CONSTRUCTION

Bolt holes on front and rear flanges

Fully welded construction

Security bars (mounted in sleeve)

Horizontal mount up flow or down flow configurations

For higher velocities & temperatures, please consult factory

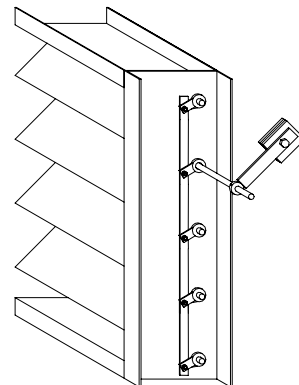

Concealed Linkage (Optional)

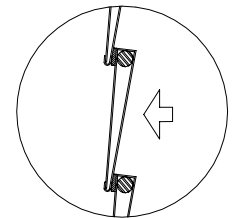

Blade Edge Seal

DATE	ARCHITECT/ENGINEER			CUSTOMER
PROJECT				
ITEM	QTY	W	H	DESCRIPTION

All tests performed at an independent laboratory and based on AMCA standards for air performance.

AIR PERFORMANCE

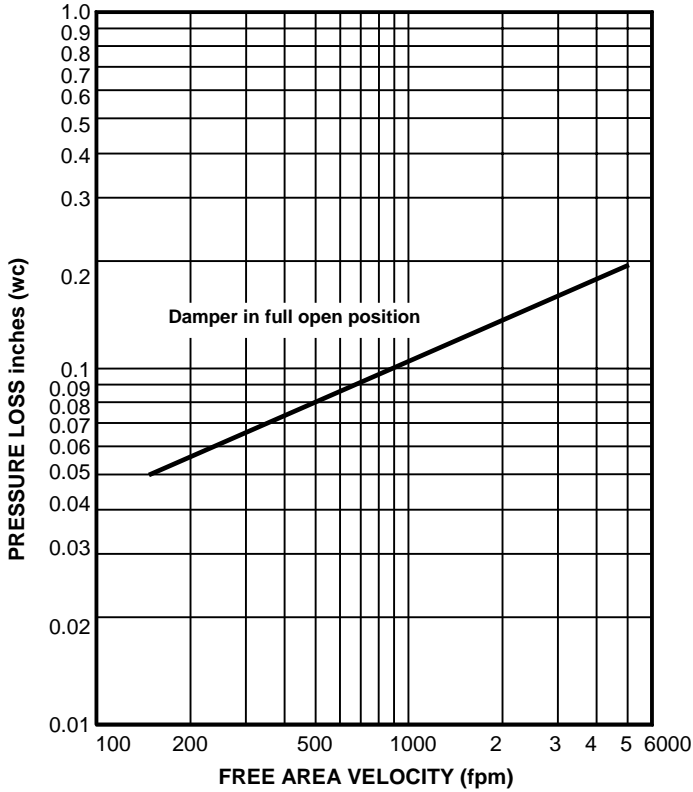

AIR LEAKAGE

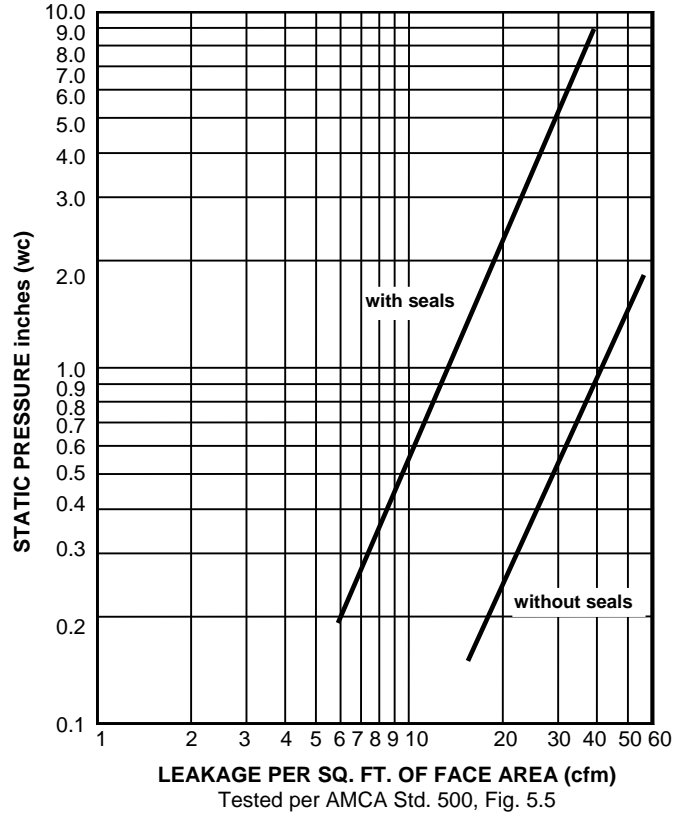

SH-2 Performance Data

Damper Width Inches	Max. Pressure	Maximum System Velocity	Leakage w/ seals / sq. ft.	Leakage w/out seals / sq. ft.
60"	9" w.g.	4000 fpm	13 cfm	40 cfm
48"	8" w.g.	4000 fpm	13 cfm	40 cfm
36"	10" w.g.	4000 fpm	13 cfm	50 cfm
24"	12" w.g.	4000 fpm	15 cfm	60 cfm
12"	15" w.g.	4000 fpm	18 cfm	100 cfm

* Leakage information based on 1" w.g. static pressure.

FREE AREA CALCULATIONS WIDTH

Inches	12	16	20	24	28	32	36	40	44	48
12	0.50	0.70	0.90	1.10	1.30	1.50	1.70	1.90	2.10	2.30
16	0.75	1.05	1.35	1.65	1.95	2.25	2.55	2.85	3.15	3.45
20	0.95	1.33	1.72	2.10	2.48	2.86	3.24	3.62	4.00	4.38
24	1.16	1.62	2.08	2.54	3.01	3.47	3.93	4.39	4.86	5.32
28	1.36	1.90	2.45	2.99	3.53	4.08	4.62	5.17	5.71	6.25
32	1.61	2.25	2.90	3.54	4.18	4.83	5.47	6.12	6.76	7.40
36	1.81	2.54	3.26	3.99	4.71	5.44	6.16	6.89	7.61	8.34
40	2.02	2.82	3.63	4.43	5.24	6.05	6.85	7.66	8.47	9.27
44	2.22	3.11	3.99	4.88	5.77	6.66	7.54	8.43	9.32	10.21
48	2.47	3.46	4.44	5.43	6.42	7.41	8.39	9.38	10.37	11.36
52	2.67	3.74	4.81	5.88	6.95	8.02	9.08	10.15	11.22	12.29
56	2.88	4.03	5.18	6.33	7.48	8.63	9.78	10.93	12.08	13.23
60	3.08	4.31	5.54	6.77	8.00	9.23	10.47	11.70	12.93	14.16
64	3.33	4.66	5.99	7.32	8.65	9.98	11.32	12.65	13.98	15.31
68	3.53	4.94	6.36	7.77	9.18	10.59	12.01	13.42	14.83	16.24
72	3.73	5.23	6.72	8.22	9.71	11.20	12.70	14.19	15.68	17.18
76	3.98	5.58	7.17	8.77	10.36	11.95	13.55	15.14	16.73	18.33
80	4.19	5.86	7.54	9.21	10.89	12.56	14.24	15.91	17.59	19.26
84	4.39	6.15	7.90	9.66	11.42	13.17	14.93	16.68	18.44	20.20
88	4.59	6.43	8.27	10.11	11.94	13.78	15.62	17.46	19.29	21.13
92	4.84	6.78	8.72	10.66	12.59	14.53	16.47	18.41	20.34	22.28
96	5.05	7.07	9.08	11.10	13.12	15.14	17.16	19.18	21.20	23.22