

Heavy Duty Back Draft Round Damper – Model HTR-3BD

STANDARD CONSTRUCTION

FRAME

Steel channel, dimensions vary according to size, see chart below

BLADES

Steel, dimensions vary according to size, see chart below

BLADE AXLES & BEARINGS

AXLE – Continuous steel shaft

BEARING – Sleeve type stainless steel

BLADE STOP

3/8" X 3/8"

MAXIMUM VELOCITY & STATIC PRESSURE

See Schedule Below

MIN. & MAX. TEMPERATURE

-40° F to 250° F

MAXIMUM SIZE

60" Diameter

MINIMUM SIZE

6" Diameter

FINISH

Shop Primer

ACTUATOR

None

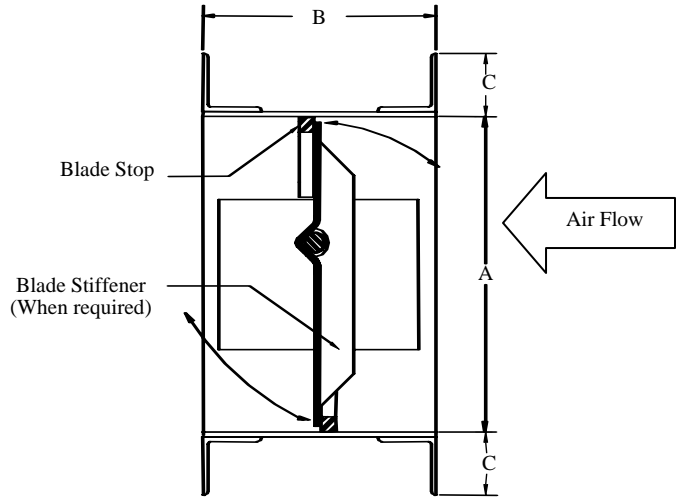
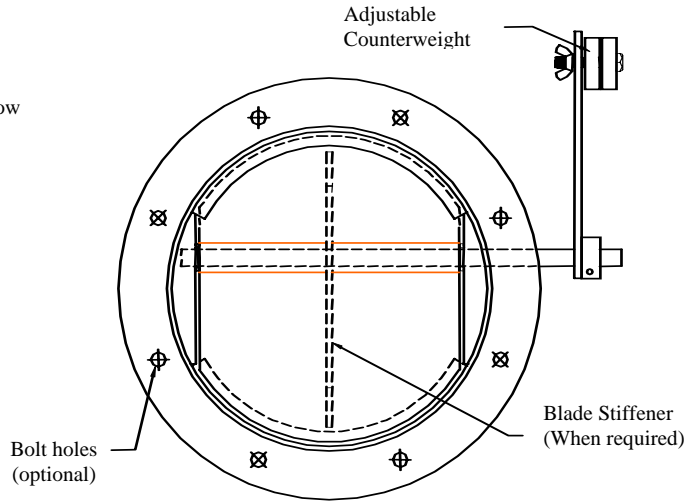

OPTIONAL CONSTRUCTION

SPECIFIED MATERIAL – Available in 304 & 316 stainless steel

FINISH – Air-dry primer, polyurethane, epoxy, or enamel. Baked epoxy or enamel. For industrial special purpose coating, please consult Dowco.

BOLT HOLES – Based on standard bolt circles available

Bolt holes start perpendicular to blade axles. (12 o'clock)

SPECIAL PURPOSE CONSTRUCTION

For higher temperatures and velocities, please consult Dowco.

Size I. D.	Flange to Flange Depth & Thickness	Flange	Blade Thickness	Axle Diameter	Maximum Static Pressure	Maximum Velocity
4" to 9"	6" x 1/8"	1-1/4" x 10ga.	10ga.	1/2"	10" wg.	6000 fpm
>9" to 11"	8" x 1/8"	1-1/4" x 10ga.	10ga.	1/2"	10" wg.	6000 fpm
>11" to 14"	8" x 1/8"	1-1/2" x 10ga.	10ga.	1/2"	8" wg.	6000 fpm
>14" to 24"	8" x 3/16"	1-1/2" x 10ga.	10ga.	3/4"	8" wg.	6000 fpm
>24" to 32"	8" x 3/16"	2" x 3/16"	10ga.	3/4"	8" wg.	5000 fpm
>32" to 44"	8" x 3/16"	2" x 3/16"	10ga.	3/4"	6" wg.	4000 fpm
>44" to 48"	8" x 3/16"	2" x 3/16"	10ga.	1"	6" wg.	4000 fpm
>48" to 52"	8" x 3/16"	2" x 3/16"	10ga.	1"	6" wg.	4000 fpm
>52" to 60"	8" x 3/16"	2-1/2" x 1/4"	1/4"	1"	6" wg.	4000 fpm

DATE	ARCHITECT / ENGINEER			CUSTOMER	
PROJECT					
ITEM	QTY	W	H	DESCRIPTION	

All tests performed at an independent laboratory and based on AMCA standards for air performance.

AIR PERFORMANCE

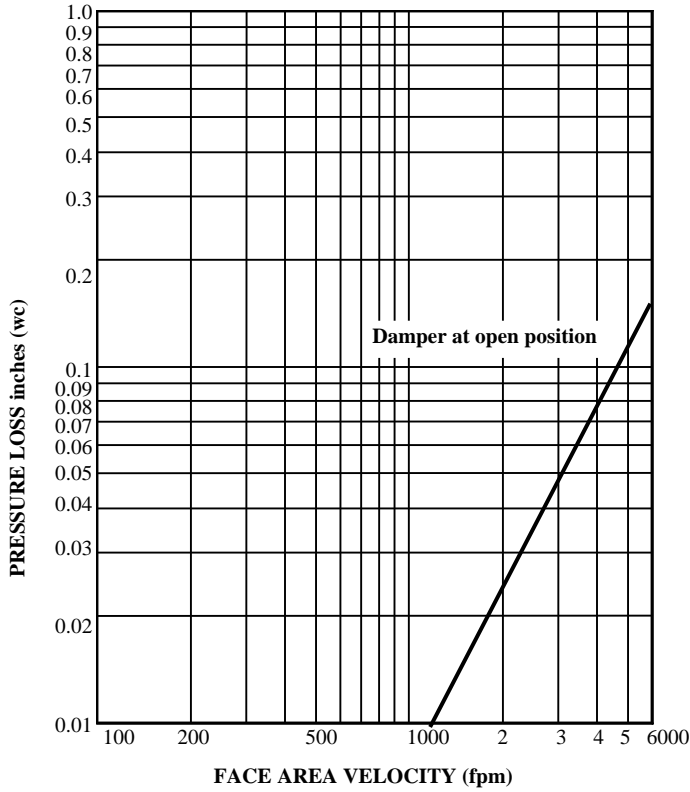

FACE AREA VELOCITY (fpm)
24" diameter sample tested per AMCA Std. 500, Figure 5.3

AIR LEAKAGE

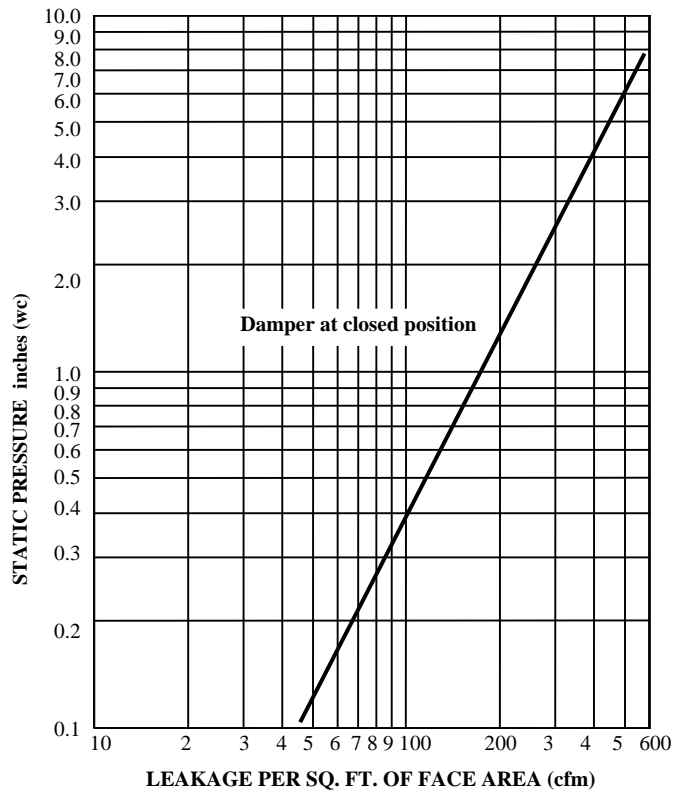

LEAKAGE PER SQ. FT. OF FACE AREA (cfm)
48" diameter sample tested per AMCA Std. 500, Figure 5.5

STANDARD BOLT HOLE PATTERN FOR HEAVY DUTY ROUND DAMPERS				
Order Size (Inches)	Flange (F)	Bolt Size (Diameter)	Number of Holes	Bolt Circle Factor
4 to 5	1"	9/32"	6	1-5/16"
6	1-1/4"	9/32"	6	1-5/16"
7	1-1/4"	3/8"	6	1-1/2"
8	1-1/4"	3/8"	6	1-9/16"
9	1-1/4"	7/16"	6	1-5/8"
10	1-1/4"	7/16"	6	1-13/16"
11	1-1/4"	7/16"	6	1-3/4"
12 to 18	1-1/2"	7/16"	8	2"
19 to 22	1-1/2"	7/16"	12	1-3/4"
23 to 24	1-1/2"	7/16"	12	1-7/8"
25	1-1/2"	7/16"	16	1-7/8"
26 to 36	2"	7/16"	16	2-3/8"
37 to 50	2"	7/16"	24	2-3/8"

- Actual I. D. Size = Order Size + 1/8"
- Actual O. D. Size = Actual I. D. Size + (F x 2)
- Bolt Circles = Order Size + Bolt Circle Factor

Bolt holes start perpendicular to blade axles (12 o'clock)

