

## Heavy Duty Industrial Round Damper – Model HTR-2

### STANDARD CONSTRUCTION

**FRAME**

Steel channel, dimensions vary according to size, see chart below

**BLADES**

Steel, dimensions vary according to size, see chart below

**BLADE AXLES & BEARINGS**

AXLE – Continuous steel shaft

BEARING – 2 Bolt flange grease lubricated

**MAXIMUM VELOCITY & STATIC PRESSURE**

6000 FPM @ 17" H<sub>2</sub>O

**MIN. & MAX. TEMPERATURE**

-40° F to 250° F

**MAXIMUM SIZE**

72" Diameter

**MINIMUM SIZE**

4" Diameter

**FINISH**

Shop Primer

**ACTUATOR**

None

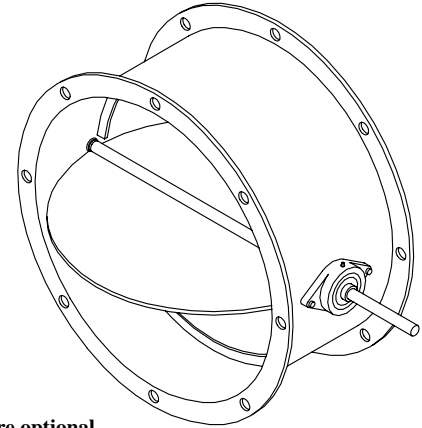

Bolt holes are optional

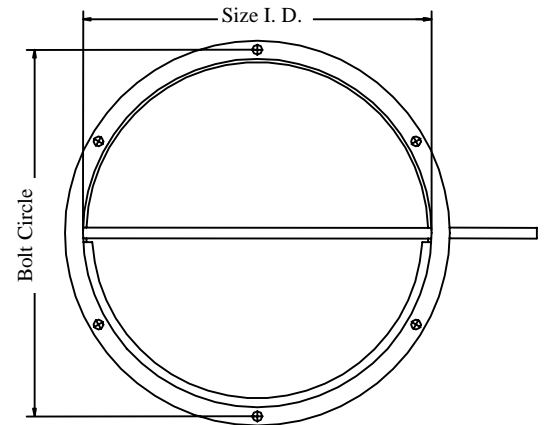

### OPTIONAL CONSTRUCTION

**SPECIFIED MATERIAL** – Available in stainless steel

**FINISH** – Air-dry primer, polyurethane, epoxy, or enamel. Baked epoxy or enamel. For industrial special purpose coating, please consult Dowco.

**BOLT HOLES** – Based on standard bolt circles available

**ACTUATORS** – Manual, Electric, or Pneumatic.

### SPECIAL PURPOSE CONSTRUCTION

For higher temperatures and velocities, please consult Dowco.

Size I. D.	Frame Depth & Web Thickness	Flange	Blade Thickness	Axle Diameter	Maximum Static Pressure	Maximum Velocity
4" to 9"	6" x 1/8"	1-1/4" x 10ga.	1/4"	1/2"	17" wg.	6000 fpm
>9" to 11"	9" x 1/8"	1-1/4" x 10ga.	1/4"	3/4"	17" wg.	6000 fpm
>11" to 14"	9" x 1/8"	1-1/2" x 10ga.	1/4"	3/4"	15" wg.	6000 fpm
>14" to 24"	9" x 1/8"	1-1/2" x 10ga.	1/4"	3/4"	15" wg.	6000 fpm
>24" to 32"	9" x 1/4"	2" x 1/4"	1/4"	3/4"	14" wg.	6000 fpm
>32" to 44"	9" x 1/4"	2" x 1/4"	1/4"	1"	14" wg.	6000 fpm
>44" to 48"	9" x 1/4"	2" x 1/4"	1/4"	1-1/2"	13" wg.	6000 fpm
>48" to 52"	9" x 1/4"	2" x 1/4"	1/4"	1-1/2"	13" wg.	6000 fpm
>52" to 72"	9" x 5/16"	2-1/2" x 5/16"	3/8"	2"	13" wg.	6000 fpm

DATE		ARCHITECT / ENGINEER			CUSTOMER	
PROJECT						
ITEM	QTY	W	H	DESCRIPTION		

All tests performed at an independent laboratory and based on AMCA standards for air performance.

### AIR PERFORMANCE

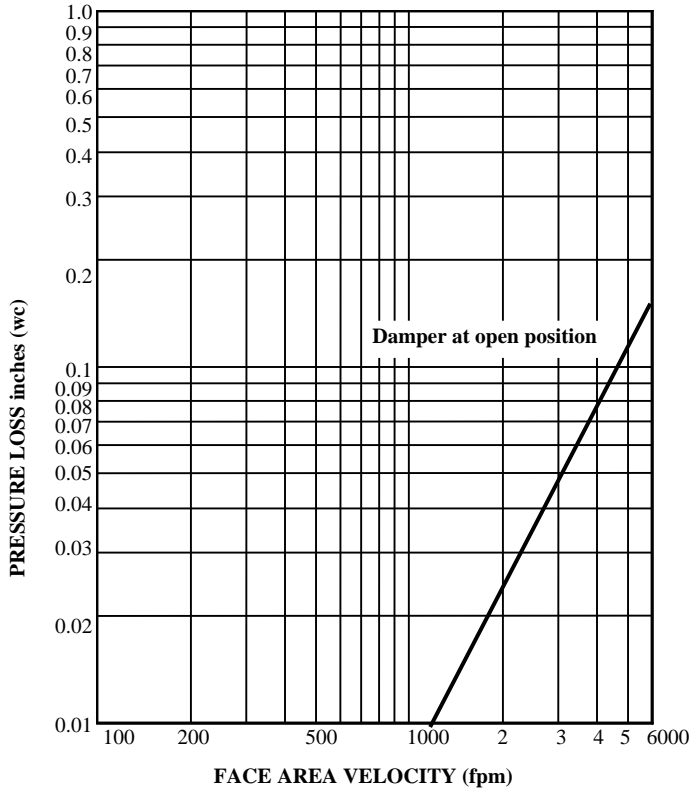

24" diameter sample tested per AMCA Std. 500, Figure 5.3

### AIR LEAKAGE

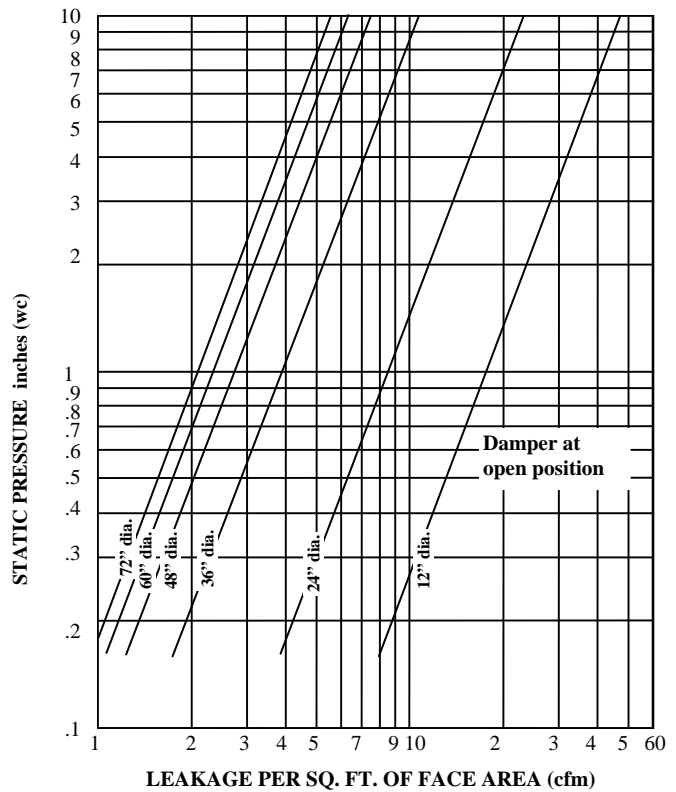

STANDARD BOLT HOLE PATTERN FOR HEAVY DUTY ROUND DAMPERS				
Order Size (Inches)	Flange (F)	Bolt Size (Diameter)	Number of Holes	Bolt Circle Factor
4 to 5	1"	9/32"	6	1-5/16"
6	1-1/4"	9/32"	6	1-5/16"
7	1-1/4"	3/8"	6	1-1/2"
8	1-1/4"	3/8"	6	1-9/16"
9	1-1/4"	7/16"	6	1-5/8"
10	1-1/4"	7/16"	6	1-13/16"
11	1-1/4"	7/16"	6	1-3/4"
12 to 18	1-1/2"	7/16"	8	2"
19 to 22	1-1/2"	7/16"	12	1-3/4"
23 to 24	1-1/2"	7/16"	12	1-7/8"
25	1-1/2"	7/16"	16	1-7/8"
26 to 36	2"	7/16"	16	2-3/8"
37 to 50	2"	7/16"	24	2-3/8"

Size Diameter	Leakage Performance Per SF. Of Face Area	
	Leakage W/seals (CFM)	Leakage w/out seals (CFM)
72	2.1	9.44
60	2.27	11.12
48	2.76	13.52
36	3.92	17.16
24	7.88	26.26
12	18.92	61.78

- Actual I. D. Size = Order Size + 1/8"
- Actual O. D. Size = Actual I. D. Size + (F x 2)
- Bolt Circles = Order Size + Bolt Circle Factor

Bolt holes start perpendicular to blade axles (12 o'clock)

