

Static Curtain Fire Damper - MODEL 300C-RC

Features – U. L. Rated for 3 hour fire damper, for use in a 4 hour fire partition. • Meets NFPA 90A & UL555

STANDARD CONSTRUCTION

FRAME

4-7/8" deep, 22 gauge galvanized steel

BLADES

3-3/8" wide, 22 gauge galvanized steel

UNDERSIZED

1/4" under ordered size unless specified otherwise

FUSIBLE LINK

165° Standard (others available)

SPRING

Stainless Steel – 301 Negator type
(Standard for Horizontal mount only)

MINIMUM SIZE

4"w x 4"h (Vertical & Horizontal)

MAXIMUM SINGLE SECTION SIZE (Duct Size)

Vertical – 22"w x 20"h

Horizontal – 46"w x 42"h

MAXIMUM MULTIPLE SECTION SIZE

Vertical – 46"w x 42"h

Horizontal – 70"w x 68"h

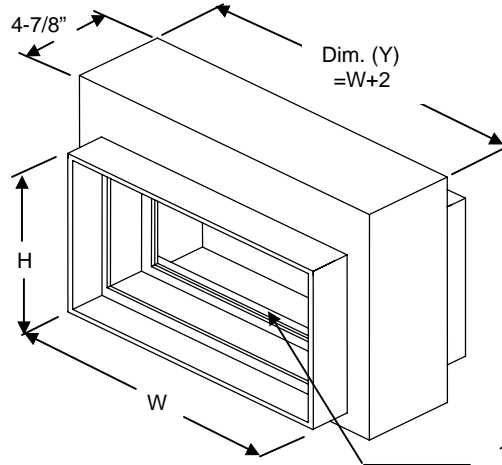
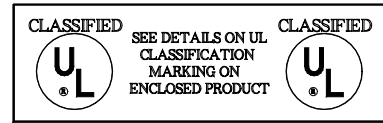

Duct Height	Dim. (X)
4" thru 15"	2"
16" thru 27"	3"
28" thru 39"	4"
40" thru 55"	5"
40" thru 43" (Horizontal Only)	

OPTIONAL CONSTRUCTION

SPRING - Available in vertical mount

FRAME – Available in Stainless Steel

BLADE – Available in Stainless Steel

FUSIBLE LINK – Electrically triggered link (ETL)

SLEEVE & DUCT CONNECTION – 10 ga. to 20 ga. galvanized steel to 30" in length. – transitions available in; round, oval, rectangular, or custom. Factory can install access door, retaining angles, flange connections or security bars.

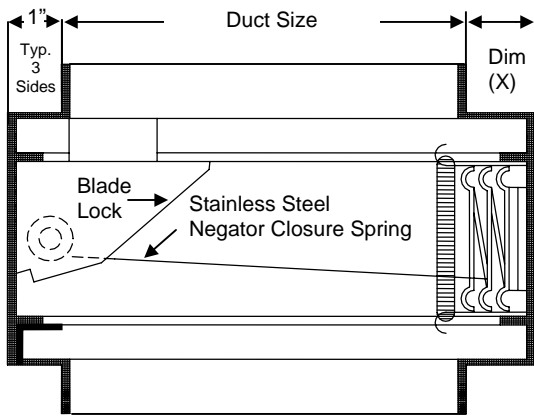

Horizontal Section

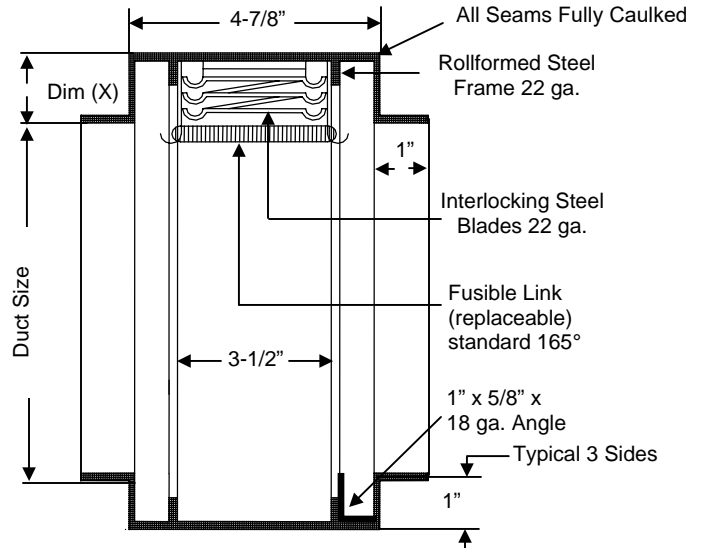

Vertical Section

DATE	ARCHITECT			CUSTOMER
PROJECT				
ITEM	QTY	W	H	DESCRIPTION



DEPENDABLE PRODUCTS SINCE 1955

SAFE-AIR/DOWCO

Engineering and General Offices

1855 South 54th Avenue, Cicero, Illinois 60804

Phone 708-652-9100 FAX 708-652-9158