

## Static Curtain Fire Damper - MODEL 150C-RC

**Features** – U. L. Rated for 1-1/2 hour fire damper, for use in a 2 hour fire partition. • Meets NFPA 90A & UL555

### STANDARD CONSTRUCTION

**FRAME**

4-7/8" deep, 22 gauge galvanized steel

**BLADES**

3-3/8" wide, 22 gauge galvanized steel

**UNDERSIZED**

1/4" under ordered size unless specified otherwise

**FUSIBLE LINK**

165° Standard (others available)

**SPRING**

Stainless Steel – 301 Negator type  
(Standard for Horizontal mount only)

**MINIMUM SIZE**

4" w x 4" h (Vertical & Horizontal)

**MAXIMUM SINGLE SECTION SIZE (Duct Size)**

Vertical – 58" w x 54" h  
Horizontal – 46" w x 42" h

**MAXIMUM MULTIPLE SECTION SIZE**

Vertical – 118" w x 74" h (40" x 40" Single Section)  
Horizontal – 95" w x 36" h (36" x 42" Single Section)

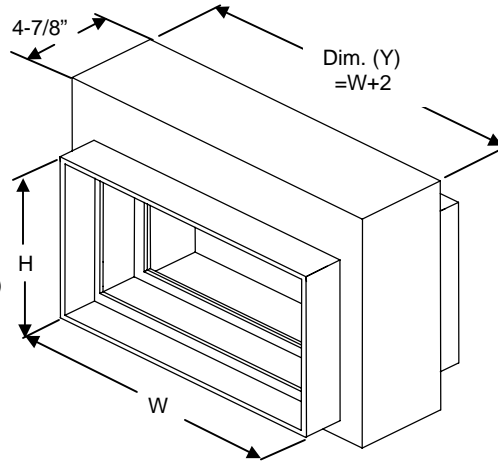
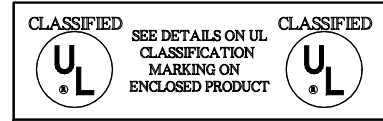

Duct Height	Dim. (X)
4" thru 15"	2"
16" thru 27"	3"
28" thru 39"	4"
40" thru 55"	5"
40" thru 43" (Horizontal Only)	

### OPTIONAL CONSTRUCTION

**SPRING** - Available in vertical mount

**FRAME** – Available in Stainless Steel

**BLADE** – Available in Stainless Steel

**FUSIBLE LINK** – Electrically triggered link (ETL)

**SLEEVE & DUCT CONNECTION** – 10 ga. to 20 ga. galvanized steel to 30" in length. – transitions available in; round, oval, rectangular, or custom. Factory can install access door, retaining angles, flange connections or security bars.

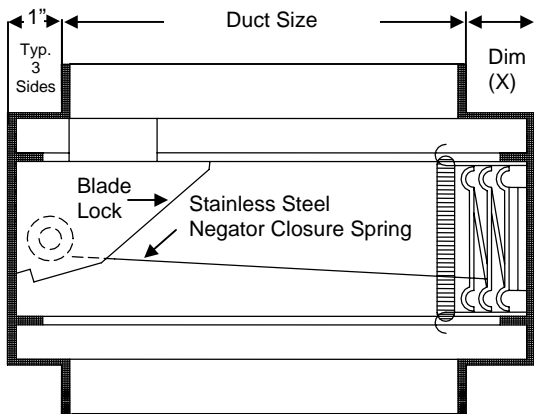

Horizontal Section

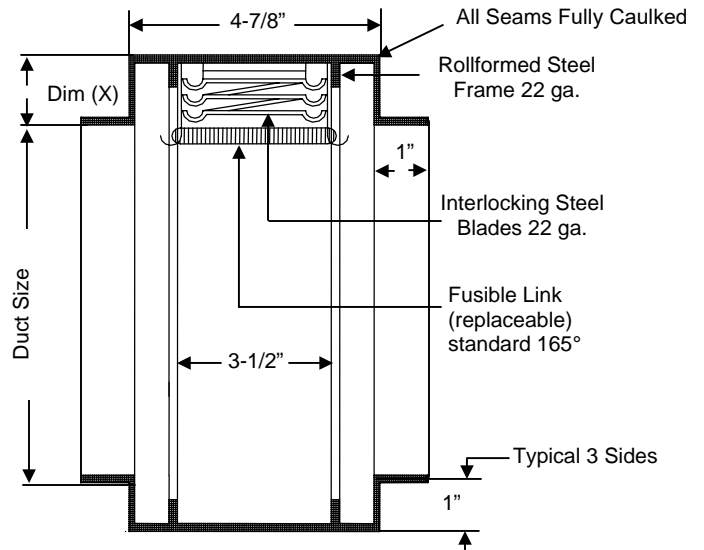

Vertical Section

DATE	ARCHITECT			CUSTOMER
PROJECT				
ITEM	QTY	W	H	DESCRIPTION



DEPENDABLE PRODUCTS SINCE 1955

**SAFE-AIR/DOWCO**

Engineering and General Offices

1855 South 54<sup>th</sup> Avenue, Cicero, Illinois 60804

Phone 708-652-9100 FAX 708-652-9158