

QUALIFICATIONS:

- **UL 263 CLASSIFIED CEILING RADIATION DAMPER.** Category CABS. (File # R8147).
- **1 hour rated for use in UL floor/ceiling design numbers L550/L562/L574/L579/L585/M501/M503 and roof/ceiling design numbers P531/P538/P545/P547/P552. (Other proprietary UL design numbers may be similar. Local approval by AHJ is required to use a Safe-Air Dowco design when not specified).**
- **Meets NFPA 90A requirements.**

DESCRIPTION:

Ceiling dampers are designed to function as a heat barrier in air handling openings penetrating fire resistive membrane ceilings. Model Series 0457 has been especially designed and tested to provide protection and simple installation in specific UL design wood truss ceiling assemblies.

Model 0457 rectangular ceiling damper requires a field fabricated steel or fiberglass plenum (boot/register box) by others, that accommodates a steel grille, register or diffuser.

STANDARD CONSTRUCTION:

1. **Fusible Link:** UL Listed, 212°F (100°C), standard.
2. **Blades:** 22 ga. (0.85) G60 roll-formed galv. steel.
3. **Blade Insulation:** Non-asbestos UL Classified.
4. **Damper Frame:** 24 ga. (0.70) galvanized steel.
5. **Flange:** 7/8" (22) plaster flange.

OPTIONS:

1. Non-standard temp. UL listed fusible link
 165 165°F (74°C)
2. Damper Style:
 420 Butterfly (Two Blades) Damper standard
 421 Single Blade Damper
3. Installation Support Angles. 26" (660) long.
 ISA 2 @ 3/4" x 3/4" x 16 ga. (19 x 19 x 1.6) or
 ISB 2 @ 1 1/2" x 1 1/2" x 22 ga. (38 x 38 x 0.85)

NOTES:

1. See page 2 for Field Supplied Steel or Fiberglass Plenum construction details.
2. Shipped loose, the ceiling damper is a component of damper/plenum box assembly.
3. See Models 0456 and 0457-CB/DB/EB for Factory Supplied Steel Plenum (by Nailor).

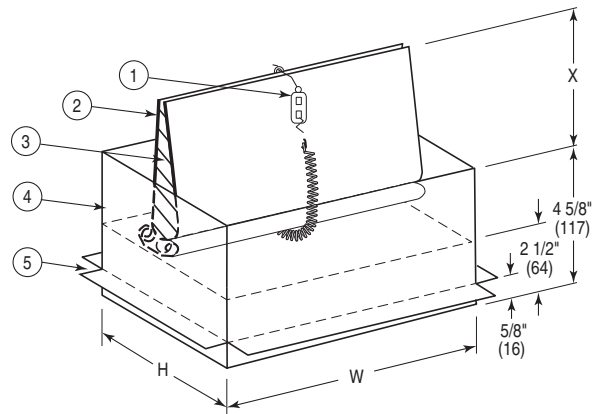

NOTE:
 X = 1/2 THE LISTED HEIGHT - 1 7/8" (48)

Note:

420 style damper shown. 421 Single Blade, which places the damper out of the airstream, is also available.

AVAILABLE SIZES:

Minimum: 6" W x 4" H (152 x 102).

Maximum with Steel Plenum:

16" W x 12" H, 12" W x 12" H or 14" W x 8" H (406 x 305, 305 x 305 or 356 x 203) dependent on plenum type.

Maximum with Fiberglass Plenum:

21" W x 18" H (533 x 457).

W x H = Nominal Grille/Register Size

For installation instructions, see IOM-SA-CRD0457INST.

SCHEDULE TYPE:				
PROJECT:				
ENGINEER:	DATE	A SERIES	SUPERSEDES	DRAWING NO.
CONTRACTOR:	4 - 30 - 19	0400-SA	NEW	0457

Steel Plenum (by OTHERS) (Type A shown)

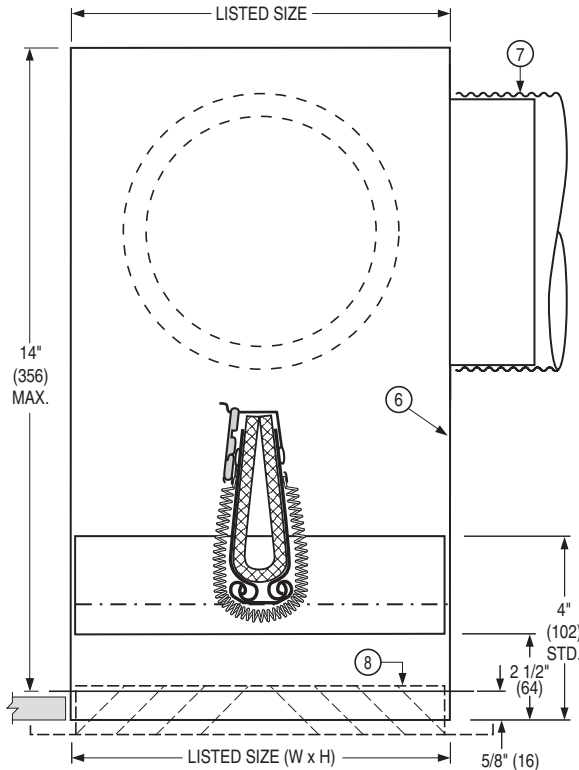

Fiberglass Plenum (by OTHERS)

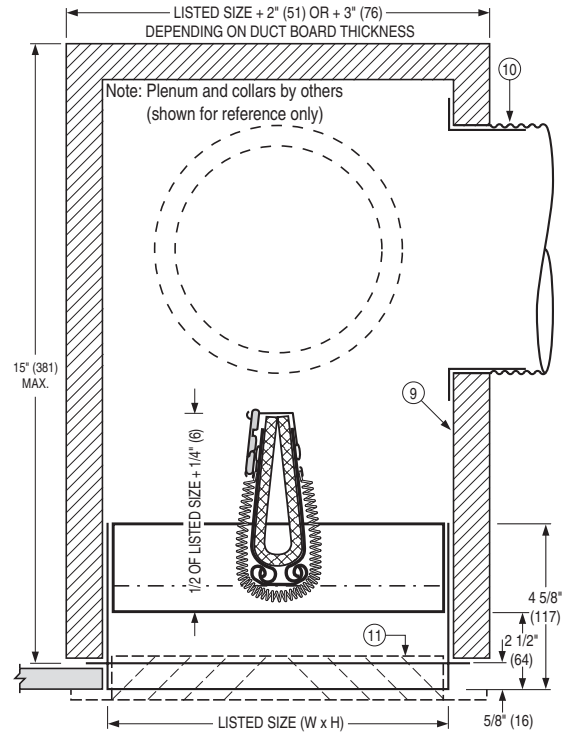

Plenum Construction	Plenum Type	Description/Installation	Min. Damper Size	Max. Damper Size	Max. No. of Collars
Steel	A	90° Side Inlet	6 x 4 (152 x 102)	16 x 12 (406 x 305)	5
	C	90° Side Inlet, Insulated	8 x 4 (203 x 102)	12 x 12 (305 x 305)	1
	D	90° Side Inlet, Tapered	8 x 4 (203 x 102)	14 x 8 (356 x 203)	1
	E	Tapered, Top Inlet	8 x 4 (203 x 102)	12 x 12 (305 x 305)	1

STEEL PLENUM

CONSTRUCTION DETAILS:

- Steel plenum/sub-frame:
 - Uninsulated: 26 ga. (0.55) min. galv. steel with round connection collar.
 - Insulated: 28 ga. (0.47) min. galv. steel
 - Insulation: Semi rigid Type R-6, 1 1/2" (28) or Type R-8, 2" (51) fiberglass duct liner, minimum density 1.5 pcf.
- UL Classified Class 0 or I Flexible Air Duct connection by others.
- Steel grille/register/diffuser, 26 ga. (0.55) min., (by Safe-Air Dowco or others). Bottom of damper sub-frame is flush with ceiling. Standard depth for grille clearance is 2 1/2" (64).

Plenum Construction	Plenum Type	Description/Installation	Min. Damper Size	Max. Damper Size	Max. No. of Collars
Fiberglass	A	90° Side Inlet	6 x 4 (152 x 102)	21 x 18 (533 x 457)	5

FIBERGLASS PLENUM

CONSTRUCTION DETAILS:

- Fiberglass plenum/sub-frame:
 - Duct Board: 1" - 1 1/2" (25 - 38), rigid (R4 - R6)
- Cutting and Installation of collar for UL Classified Class 0 or I Flexible Air Duct connection by others.
- Steel grille/register/diffuser, 26 ga. (0.55) min., (by Safe-Air Dowco or others). Bottom of damper sub-frame is flush with ceiling. Standard depth for grille clearance is 2 1/2" (64).

NOTES:

- See minimum/maximum damper size restriction by Plenum Construction/Plenum Type, above.
- Refer to document IOM-SA-CRD0457INST for Supplementary Installation Instructions for Field Fabrication of Steel or Fiberglass Plenums (by others).

SCHEDULE TYPE:				
PROJECT:				
ENGINEER:	DATE	A SERIES	SUPERSEDES	DRAWING NO.
CONTRACTOR:	4 - 30 - 19	0400-SA	NEW	0457