

FRONT ELEV.
16 THUS REQ'D.

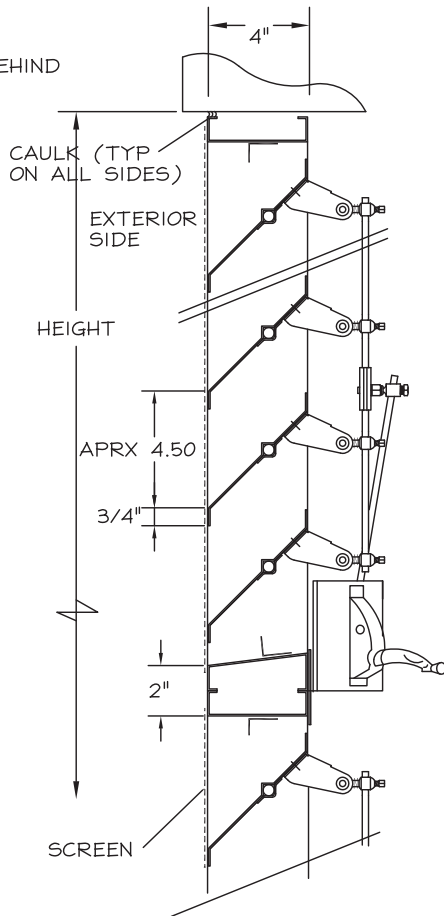

SECTION "B"

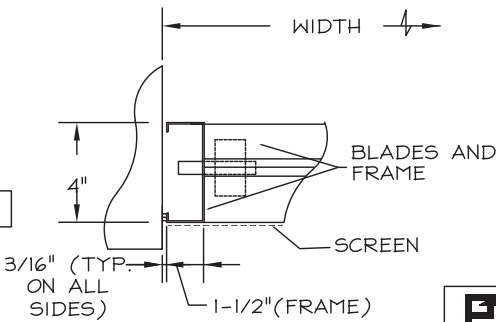

SECTION "A"

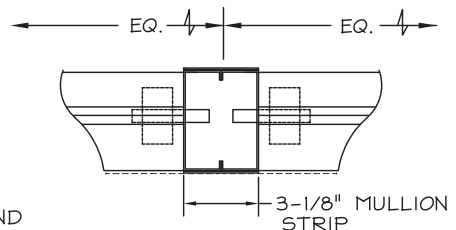

SECTION "C"

STANDARD CONSTRUCTION

MODEL: AFC-04-300F-BX
 FRAME: 16 GA. GALV. STEEL
 BLADES: 16 GA. GALV. STEEL
 BEARINGS: 1/2" DIA. BRONZE OILITE
 AXLES: 1/2" DIA. PLATED STEEL
 LINKAGE: PLATED STEEL
 SCREEN: 1/2 MESH X 19 GA. GALV. IN FRAME ON FACE
 FINISH: NATURAL MILL
 OPERATOR: (4) CRANK OPERATORS PER UNIT

- NOTES:
1. ALL LOUVERS TO BE FABRICATED 3/8" UNDER LISTED OPNG. SIZES UNLESS SPECIFIED "ACTUAL".
 2. ALL OPNG SIZES TO BE FIELD VERIFIED AND GUARANTEED BY OTHERS PRIOR TO FABRICATION.
 3. OTHER SURROUNDING FINISHES ARE FOR REFERENCES ONLY AND TO BE SUPPLIED BY OTHERS.

LOUVER SCHEDULE

TAG QTY OPNG SIZE (WXH) NOTES

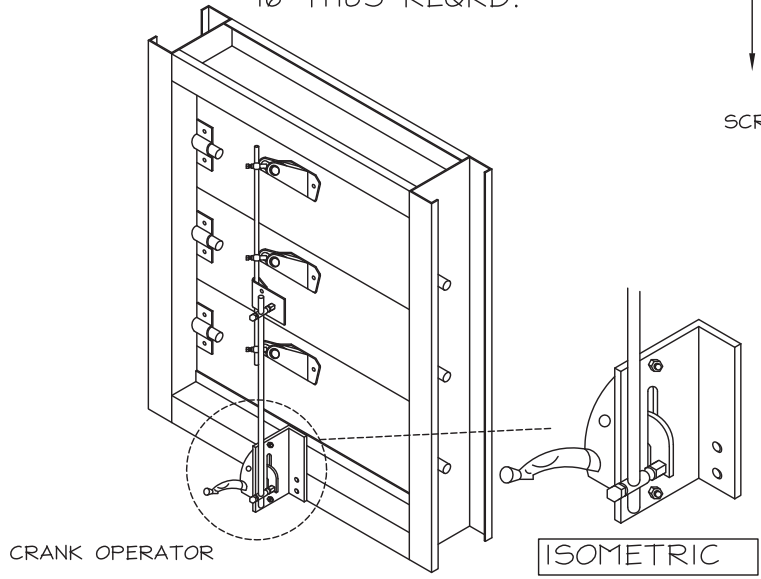

CRANK OPERATOR

ISOMETRIC

 DOWCO DEPENDABLE PRODUCTS SINCE 1955 1855 SOUTH 54TH AVENUE, CICERO, IL. 60650	
ARCH/ENGR:	CUSTOMER:
PROJECT:	TITLE: AFC-04-series
DATE:	DRAWN: JN CHKD:

REV.	DESCRIPTION	DATE	BY