

## FIRE / SMOKE DAMPER MODELS -771 & 772 OP MASONRY, CONCRETE, WOOD AND STEEL STUD/GYPSUM WALLBOARD INSTALLATION INSTRUCTIONS

Supplemental Instructions refer also to model 771/772 basic installation instructions.

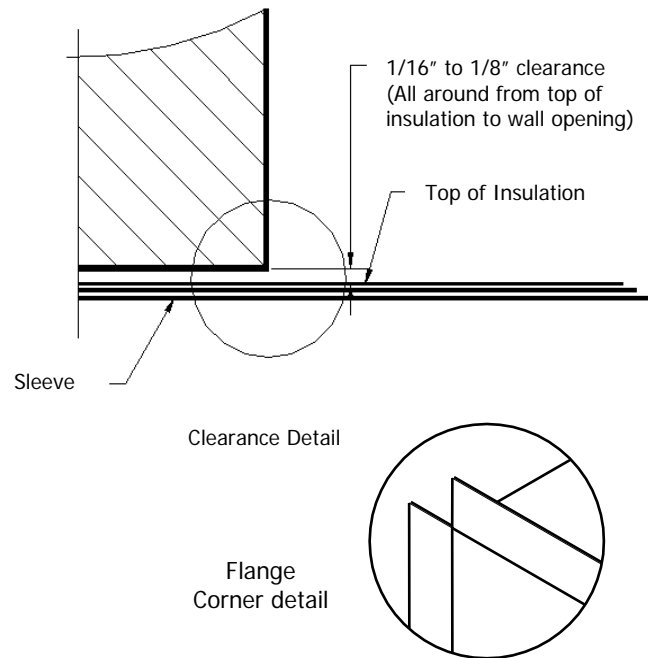
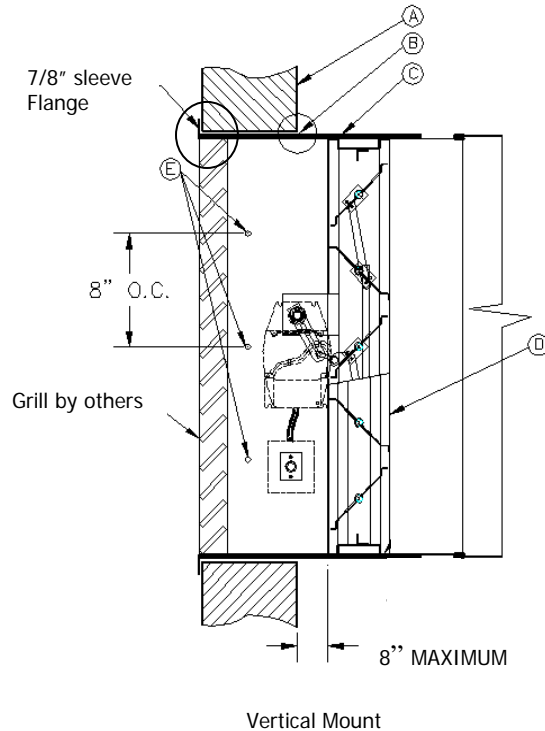

### Typical Installation Details

- (A) Wall Opening refer to framing instructions for damper installed in gypsum board partitions
- (B) Clearance: 1/8" – 1/4" larger than overall outside dimensions of sleeve including insulation.
- (C) Steel sleeve factory provided covered with factory provided insulation.
- (D) Fire Damper 771 & 772 OP
- (E) Sleeve shall be secured to inside perimeter of wall opening as follows:  
Masonry / Concrete Wall - Min. 3/16" diameter, 1-1/2" long steel concrete anchors w/screws, or self-tapping masonry screws. Fasteners 8" OC, 2" max. from each corner.  
Steel Stud / Gypsum Board Partition - Min. No. 10 steel screws be 1-1/4" long. Fasteners located 8" OC, 2" max. from each corners.

#### Notes:

1. Maximum distance out of wall for damper is to be no greater than 8." This distance is measured from the rear of the damper to the exposed wall face.
2. 1/4" Insulation consist of (2) layers of factory installed 1/8" thick insulation.

### Installation – Failure to follow these instructions will void all warranties.

These instructions apply to 1 1/2" hour rated combination fire smoke dampers mounted (blades must be horizontal) in: 1) masonry, block or stud walls. Specific requirements in these instructions are mandatory. Dampers must be installed in accordance with these instructions to meet the requirements of UL 555 and UL 555S. The installation of the damper and all duct connections to the damper sleeve shall conform to the latest editions of NFPA 90A, Standard for the installation of Air Conditioning and Ventilating Systems, and the SMACNA Fire, Smoke and Radiation damper installation guide, and U.L. Classifications R7861.

### Clearances Required between Fire Damper Sleeves and Wall/Floor Openings.

Fire damper and sleeve assemblies expand during periods of intense heat. Therefore, it is essential that openings in walls be larger than the fire/smoke damper and sleeve assembly to allow for this expansion. Clearance requirements between sleeve and wall or floor shall be minimum of 1/8 per foot of width and height of sleeve. The maximum size of opening shall be 2" larger in width or height than the allowed minimum size, see clearance detail shown above.



## OPERATION AND MAINTENANCE INTRUCTIONS

### FIRE & SMOKE AND SMOKE DAMPERS

This operation and maintenance instructions should not serve as a standard basis for all damper products and other manufacturers, but for Safeair-Dowco damper products.

All fire smoke and smoke dampers require routine maintenance procedures in order for dampers to operate as intended in any case in which fire and smoke may occur within the building. Periodic testing of all parts linked to the damper is essential to maintaining a working damper. Check that all actuators, blades, fans, etc. are functioning properly and that nothing is preventing blades or controls from operating. Be sure to check that nothing is blocking or hindering air way passage. Safeair-Dowco recommends that each routine operation and maintenance procedure follow with NFPA92A, NFPA80 and NFPA105 requirements and local authority approvals.

#### MAINTENANCE:

1. Check interior and exterior sides of dampers for any major defects or material disintegration that may prevent proper functioning of damper.
  - a. In serious damage contact Safeair-Dowco <http://safeair-dowco.com/contact.php>
2. Re-tighten any loose linkage or attached equipment, such as actuator.
3. Shafts, bearings, pivot points etc. should be cleaned and lubricated with a light spray oil. Any and all access should be removed.
  - a. *Use silicone based lubricant and not petroleum based lubricant.*
  - b. *Dampers with non-mettalic or carbon sleeve bearings do not require lubrication*
4. Blades should be checked for freedom of movement.
5. Blades should also be disconnected from their operators and manually checked (Blades should move freely with no binding or twisting).
6. Motors (electric or pneumatic) should be visually checked through their complete cycle for defects, binding or misalignment. Operator anchorage and fittings should also be checked.
  - a. *Damper should be operated under normal airflow conditions.*
7. If in any case actuators, blades or linkage is not properly functioning, contact Safe-Air Dowco at our given inquiry page located above to be further assisted.

#### TESTING PROCEDURE:

1. With the thermal disc intact, heat the thermal disc with a temperate heat source,
  - a. *Make sure not to overheat and damage the thermal disc.*
2. Check that the thermal disc functions properly as it will activate the actuator to close the damper blades.
  - a. **(Be sure to keep hands out of path while blades are closing)**
3. When testing procedure is done and all parts are working collectively and properly, allow thermal disc to cool.
4. Reset the disc located on the outside of damper, which will then re-open the damper blades allowing airflow.
5. Record date of testing procedure and label on a sheet.
6. Repeat testing procedure on a set periodic routine.