

Powers™ Controls

RL 147 Positioning Relay

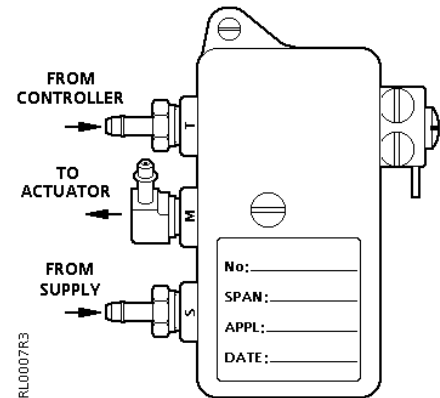

Description	The RL 147 Positioning Relay is a compact, pneumatic device designed to provide positive positioning of a pneumatic valve or damper actuator. The positioner provides supply air pressure against the actuator diaphragm to initiate stem or shaft movement. The actuator spring reverses the stem or shaft movement.	
Features	<ul style="list-style-type: none"> • Rapid response • Good repeatability • Adjustable start point pressure • Adjustable span • Low air consumption 	
Product Numbers	See Table 1.	
Specifications	Ambient Temperature Range	
Operating	Storage	-20 to 160°F (-29 to 71°C)
	Operation	35 to 160°F (2 to 71°C)
	Maximum Pilot Signal Pressure	30 psig (207 kPa)
	Maximum Supply Air Pressure	60 psig (413 kPa)
	Start Point Adjustment Range	3 to 10 psig (21 to 69 kPa)
	Operating Span Adjustment Range	3 to 12 psig (21 to 83 kPa)
	Response	1/10 psi Input change (0.7 kPa)
	Air Capacity @ ΔP = 2 psi (14 kPa)	410 scim (112 ml/s)
	Air Consumption	40 scim (11 ml/s)
Physical	Air Connections	1/8-inch NPT
	Body Materials	Zinc
	Cover	Electro Plated Steel
	Dimensions	See Figure 14
	Shipping Weight, with kit	2 lb (0.9 kg)

Table 1. Product Numbers for Positioning Relay and Mounting Kits.

Description of Actuator Type	Product Numbers		Reference Page
	Positioning Relay	Mounting Kit	
No. 3 Damper Actuator For actuators manufactured after 1/1/93	147-2000	147-104	10
No. 4 Damper Actuator	147-2000	147-314	10
No. 6 Damper Actuator	147-2000	147-276	11
8-inch Valve Actuator For VF 599 Series Flowrite actuators manufactured after 3/1/96	599-00426 Contains both relay and mounting kit		12
For Model 3 Flowrite actuators manufactured between 3/1/93 and 1/1/96	147-2000	147-333	11
For Models 1 and 2 Flowrite actuators. Also order spring arm No. 147-307 for use with VF 591 5-inch and 6-inch balanced valves	147-2000	147-277	13
12-inch Valve Actuator For VF 599 Series Flowrite actuators manufactured after 1/1/96	599-00423 Contains both relay and mounting kit		12
For Flowrite actuators manufactured between 3/78 and 1/1/96	147-2000	147-311	14
For Super Flowrite and 12-inch Flowrite actuators manufactured before 3/78	147-2000	147-279	13

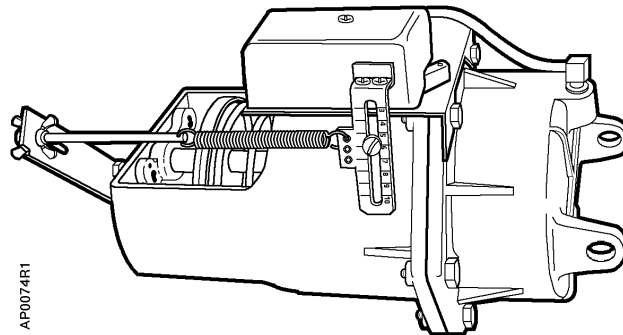

Figure 1. The RL 147 Positioning Relay Mounted on a No. 6 Damper Actuator.

Application

The Positioning Relay is recommended for damper actuator and valve applications where rapid speed of response and/or repeatability of stem position is needed to obtain good system operation. It can be used to reduce the span of controlled devices to permit sequencing. It can also be used to increase the close-off force of a normally open actuator without affecting its spring span, because the positioner uses full supply air pressure to position the actuator.

The spring range of the actuator does not affect the operation of the positioner. Therefore, it is recommended that an actuator with a high spring range, such as 8 psig to 13 psig (55 kPa to 90 kPa), be selected. This combination has the high return force of the actuator spring, plus the high forward force available from the positioner.

**Application,
 Continued**

A positioning relay can be connected to handle up to four identical No. 6 damper actuators or up to six identical No. 4 damper actuators if all actuators operate the same damper, and no more than 100 feet of 1/4-inch (6.4 mm) OD tube is used to connect them. All actuators connected this way must be identical (that is, same size, spring range, stroke, etc.).

The positioning relay is single acting and is primarily intended for use on actuators with an integral spring to return the actuator shaft to the normal position. Applications with a double acting (springless) actuator require a reversing relay to provide the additional control signal.

Operation

A rise in thermostat pressure will unbalance the lever assembly. See Figure 2. The shaft movement, through the spring arm, increases tension on the feedback spring to bring the lever assembly again into balance. A drop in thermostat pressure will unbalance the lever assembly in the opposite direction to exhaust air from the actuator until a new balance position is reached.

The positioning relay start point is adjustable. The start point adjustment nut shown in Figure 2 is used to set the start point pressure. The span adjustment screw tab location on the feedback arm and the feedback spring location on the spring guide determine the span setting of the relay.

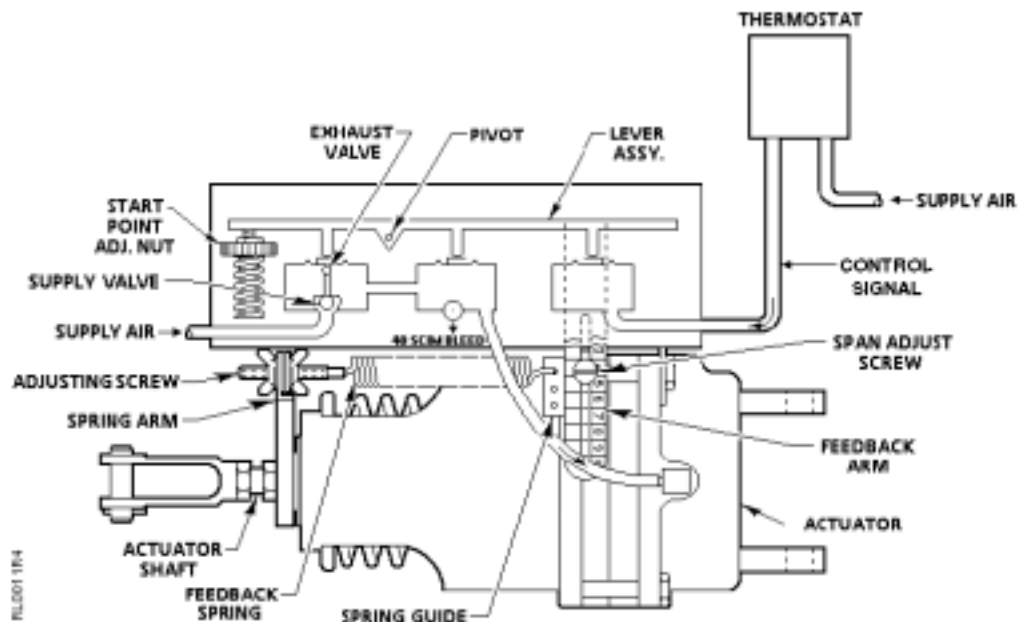

Figure 2. Operation Schematic.

Positioning Relay Components

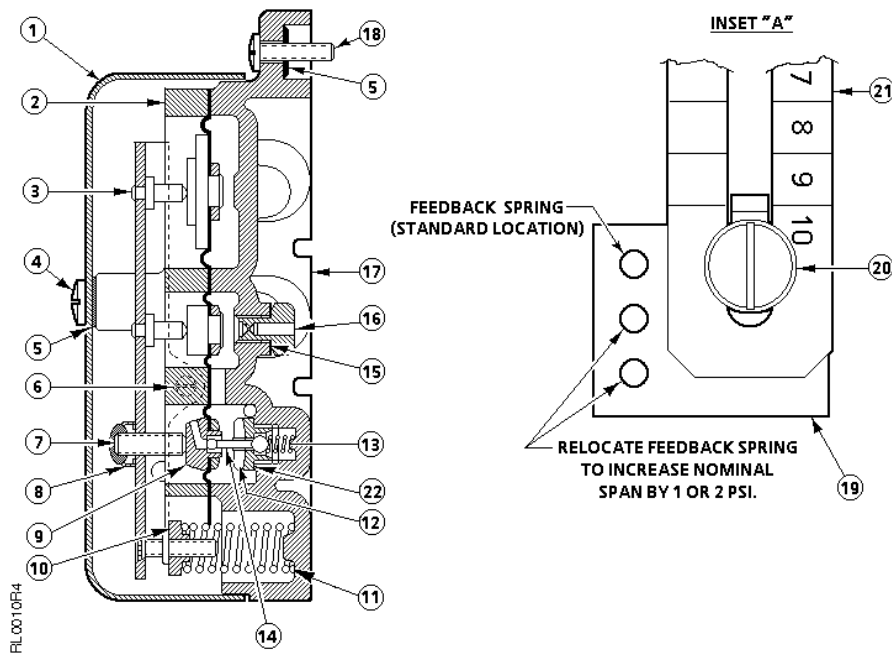

Figure 3. Construction of the RL 147 Positioning Relay.

Item	Replacement Part Number	Description	Number Required	Material
1	—	Cover	1	Steel
2	—	Plate	1	Zinc Die Casting
3	—	Lever Assembly	1	—
4	—	No. 8-32 Cover Screw	1	Steel
5	—	Washer	1	Rubber
6	147-273	Pivot Screw	2	Stainless Steel
7	—	No. 8-32 x 1/2" Lg. Dual Pt. Set Screw	1	Steel
8	—	No. 8-32 Palnut	1	Steel
9	—	Diaphragm Assembly	1	—
10	—	Start Point Adjustment Nut	1	Brass
11	—	Start Spring	1	Music Wire
12	—	Supply Valve Seat	1	Brass
13	—	Supply Valve Spring	1	Phosphor Bronze
14	—	Ball Assembly	1	Stainless Steel
15	—	Bleed Port Gasket	1	Fiber
16	—	Bleed Port	1	Brass
17	—	Base	1	Zinc Die Casting
18	034-048	No. 6-32 x 5/8" Lg. Bind Hd Screw	2	Brass
19	147-297	Spring Guide	1	Steel
20	034-067K	Span Adjustment Screw	1	Steel
21	—	Feedback Arm	1	Steel
22	—	Gasket	1	Fairprene

Calibration

Complete calibration instructions are included with each positioning relay.

1. Check that you have the correct feedback spring(s) attached.
2. Identify the desired operating span and the start point pressure.

NOTE: In some cases, the actuator stem travel or stroke is not identical to the nominal value of the relay feedback spring. See *Calculating the Span Setting* to determine the span setting on the feedback arm.

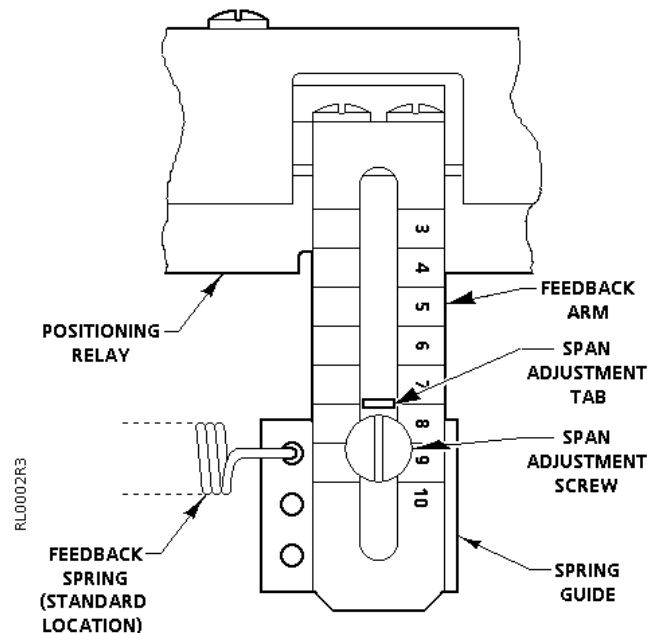

**Figure 4. Span Adjustment.
Shown at Span Setting 8.**

Setting the Span

See Figure 4.

The positioning relay operating span can be set for spans of 3 psig through 12 psig (21 kPa to 83 kPa).

For spans of 3 psig through 10 psig (21 to 69 kPa):

1. Check that the feedback spring is attached to the spring guide in the hole across from the span adjustment screw. This is identified as the standard location in Figure 4.
2. With a screwdriver, loosen the span adjustment screw. Move the spring guide on the feedback arm until the span adjustment tab is at the desired span setting reference number.

NOTE: The line to the left of the number is the setting.

3. Tighten the span adjustment screw.
4. The feedback spring must be parallel to the actuator shaft or valve stem. Use open-end wrenches to loosen the hex nuts holding the spring arm in position on the shaft or stem. Align the feedback spring and tighten the hex nuts.
5. The feedback spring should have no slack or stretch in it. Adjust the wing nuts and adjustment nut, if necessary.

Calibration, Continued

For spans of 11 psig or 12 psig (76 kPa or 83 kPa):

1. Move the span adjustment tab to the 10 setting on the feedback arm. Follow Steps 2 and 3 in *Setting the span*.
2. Move the feedback spring one hole away from the standard location for a span of 11 psig (76 kPa) and two holes away from the standard spring location for a 12 psig (83 kPa) span. See Figure 4.
3. Follow Steps 4 and 5 in *Setting the Span*.

Adjusting the Start Point

See Figure 5.

The positioning relay can be adjusted to start actuator movement at pressures between 3 psig and 10 psig (21 kPa and 69 kPa).

1. Remove the relay cover.
2. Attach tubing with a pressure gauge and squeeze bulb to the "T" Port. Supply air should be attached to the "S" Port. The "M" Port should be attached to the connector on the actuator.
3. Using the squeeze bulb, apply pressure to the relay. Watch the valve stem or actuator shaft to see when it begins to move. Check the pressure gauge; this is the start point pressure.
4. If this is not the desired start point pressure, turn the start point adjustment nut (Figure 5) clockwise to increase the start point pressure and counterclockwise to decrease the pressure.
5. Repeat Steps 3 and 4 until the stem or shaft begins to move at the desired pressure.

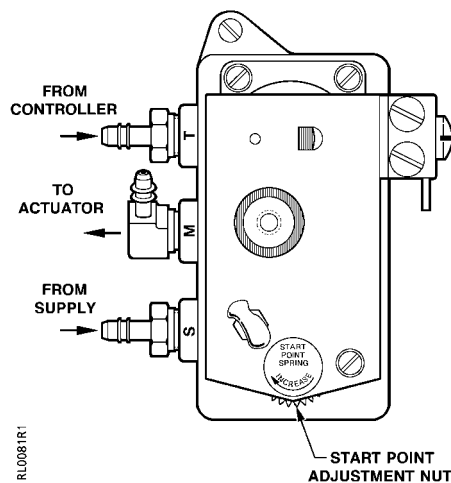

Figure 5. Start Point Adjustment.

**Calibration,
 Continued**

Adjusting the Span

1. Using the squeeze bulb, apply pressure to the relay. Note the pressure at which the stem or shaft begins to move.
2. Continue to apply pressure until the stem or shaft completes its full stroke. Note the pressure.
3. Check the difference between the two pressures; this is the span.
4. If the span is not the desired span, move the spring guide to a higher reference number to increase the span or lower number to decrease the span. See Figure 4.
5. Repeat Steps 1 through 4 until you get the desired span.
6. If you have moved the spring guide, adjust the spring arm so that the spring is parallel to the stem or shaft.
7. Check the feedback spring. There should be no slack or stretch in it. Adjust the wing nuts and adjustment nut, if necessary.
8. Fasten the relay cover. Fill in the information on the calibration label.

**Calculating the Span
 Setting**

1. Identify the valve stem from Table 3 or 4. If the stroke of the No. 6 damper actuator has been changed from the factory setting, see Table 7.
2. If your stem travel matches the nominal spring travel listed in Table 2, there is no need to calculate a new span setting.
3. If your stem travel does not match the nominal spring travel listed in Table 2, choose the spring(s) whose maximum allowable travel is equal or greater than your actual stem travel.
4. Calculate the span setting with the following formula:

Formula for Span Setting

$$\text{Span Setting} = \text{Desired span} \times \frac{\text{Nominal spring travel}}{\text{Actuator stroke}}$$

Example: Determine the span setting for a valve having a span of 5 psig and 5/16-inch stroke.

Select a spring with a maximum allowable range equal to or larger than the stroke. Use the 1/4-inch spring with a 3/8-inch maximum allowable travel range. See Table 2.

$$\text{Span Setting} = 5 \times \frac{0.25}{0.312} = 4$$

Set the span adjustment tab to line 4 on the feed back arm to provide a 5 psig span for this valve.

**Calibration,
 Continued**

Table 2. Spring Selection.

Spring Travel Range		Recommended Springs	
Nominal Inches (mm)	Max. Allowable Inches (mm)	Part Number	Size and Color
5/32 (5.0)	1/4 (6.4)	147-298	Small Green
1/4 (6.4)	3/8 (9.5)	147-289	Small Cadmium Plate
3/8 (9.5)	1/2 (13)	(2)147-298	Small Green
3/4 (19)	1 (25)	147-290	Small Red
1 (25)	1-1/4 (32)	147-291	Long Green
1-1/4 (32)	1-5/8 (41)	147-289 plus 147-291	Small Cadmium Plate plus Long Green
1-1/2 (38)	2 (51)	(2) 147-290	Small Red
1-3/4 (44)	2-1/4 (57)	147-290 plus 147-291	Small Red plus Long Green
2 (51)	2-1/2 (64)	(2) 147-291	Long Green
2-3/8 (60)	N/A	147-105	2" Red
3 (76)	3-1/4(83)	147-292	Long Cadmium Plate
3-3/4 (95)	4 (102)	147-301	3" Red
4 (102)	4-1/4 (108)	147-293	Blue
4 (102)	6 (152)	147-313	Zinc Pl. or Yell. Chr.
7 (178)	12-1/4 (311)	147-330	Zinc Plate

Table 3. Stem Travel for VP 591 Bronze Body Valves.

Line Size Inches (mm)	Stem Travel Inches (mm)		
	Single Seat	Double Seat	WM
1/2 (13)	3/8 (9.5)	—	1/8 (3.2)
3/4 (19)	3/4 (19)	—	3/16 (4.8)
1 (25)	3/4 (19)	3/16 (4.8)	1/4 (6.4)
1-1/4 (32)	1 (25)	1/4 (6.4)	5/16 (7.9)
1-1/2 (38)	1 (25)	1/4 (6.4)	5/16 (7.9)
2 (51)	5/8 (16)	3/8 (9.5) N.O. 5/16 (7.9) N.C.	5/16 (7.9)

Table 4. Stem Travel for VF 599 Valve Bodies.

Line size in Inches (mm)	Stem Travel in Inches (mm)	
	8-inch Actuator	12-inch Actuator
1/2 through 2 (15 though 50)	3/4 (20)	—
2-1/2 (65)	3/4 (20)	3/4 (20)
3 (80)	3/4 (20)	3/4 (20)
4 (100)	—	1-1/2 (40)
5 (125)	—	1-1/2 (40)
6 (150)	—	1-1/2 (40)

**Calibration,
 Continued**

Table 5. Stem Travel Listed by 591 or 593 Flowrite Valve Product Number.

Flowrite Product Number	Stem Travel Inches (mm)	Flowrite Product Number	Stem Travel Inches (mm)	Flowrite Product Number	Stem Travel Inches (mm)	Flowrite Product Number	Stem Travel Inches (mm)
591-6480	5/8 (16)	591-7872	1 (25)	591-8331	5/8 (16)	593-8390	3/4 (19)
591-6490	3/4 (19)	591-7873	1 (25)	591-8332	3/4 (19)	593-8391	3/4 (19)
591-6540	5/8 (16)	591-7874	1 (25)	591-8336	5/8 (16)	593-8392	1-1/8 (29)
591-6600	1/8 (3.2)	591-7875	3/4 (19)	591-8337	5/8 (16)	593-8393	1-1/8 (29)
591-6610	3/16 (4.8)	591-7876	3/4 (19)	591-8338	3/4 (19)	593-8394	1-1/4 (32)
591-6620	1/4 (6.4)	591-7877	1 (25)	591-8339	3/4 (19)	593-8395	1-1/4 (32)
591-6630	5/16 (7.9)	591-7878	1 (25)	591-8340	1 (25)	593-8396	1-1/4 (32)
591-6640	5/16 (7.9)	591-7879	1 (25)	591-8341	1 (25)	593-8397	1-1/4 (32)
591-6650	5/16 (7.9)	591-7971	3/8 (9.5)	591-8342	1-1/2 (38)	593-8398	1-1/4 (32)
591-6720	5/8 (16)	591-7972	3/4 (19)	591-8344	1-1/2 (38)	593-8399	1-1/4 (32)
591-6730	3/4 (19)	591-7973	3/4 (19)	591-8350	1-1/2 (38)	593-8400	1-1/4 (32)
591-6740	1 (25)	591-7974	1 (25)	591-8351	1-1/8 (29)	593-8401	1-1/4 (32)
591-6840	3/8 (9.5)	591-7975	1 (25)	591-8352	1-1/8 (29)	593-8402	1-1/2 (38)
591-6850	9/16 (14)	591-7976	1 (25)	591-8353	1-1/8 (29)	593-8403	1-1/2 (38)
591-6860	9/16 (14)	591-7977	3/8 (9.5)	591-8354	1-1/8 (29)	593-8404	1-1/4 (32)
591-6870	5/16 (7.9)	591-7978	3/4 (19)	591-8355	1-1/8 (29)	593-8405	1-1/4 (32)
591-6880	9/16 (14)	591-7979	3/4 (19)	591-8356	1-1/8 (29)	593-8406	1-1/4 (32)
591-6890	9/16 (14)	591-7980	1 (25)	591-8357	1-1/8 (29)	593-8407	1-1/4 (32)
591-6900	1/4 (6.4)	591-7981	1 (25)	591-8358	1-1/4 (32)	593-8410	1-1/2 (38)
591-6910	1/4 (6.4)	591-7982	1 (25)	591-8359	1-1/8 (29)	593-8411	1-1/2 (38)
591-6920	5/16 (7.9)	591-8016	5/8 (16)	591-8360	1-1/2 (38)	593-8412	1-3/8 (35)
591-6930	9/16 (14)	591-8017	5/8 (16)	591-8362	1-1/2 (38)	593-8413	1-3/8 (35)
591-6940	3/16 (4.8)	591-8018	3/4 (19)	591-8364	1-1/8 (29)	593-8415	1 (25)
591-6950	1/4 (6.4)	591-8019	3/4 (19)	591-8365	1-1/8 (29)	593-8416	1 (25)
591-6960	1/4 (6.4)	591-8020	1 (25)	591-8366	1-1/8 (29)	593-8419	1 (25)
591-6970	3/8 (9.5)	591-8021	1 (25)	591-8367	1-1/8 (29)	593-8420	1 (25)
591-6980	3/16 (4.8)	591-8028	5/8 (16)	591-8368	1-1/8 (29)	593-8421	1-3/8 (35)
591-6990	1/4 (6.4)	591-8029	3/4 (19)	591-8369	1-1/8 (29)	593-8422	1-3/8 (35)
591-7000	1/4 (6.4)	591-8030	1 (25)	591-8370	1-1/8 (29)	593-8423	1-3/8 (35)
591-7010	5/16 (7.9)	591-8071	3/8 (9.5)	591-8371	1-1/8 (29)	594-8343*	1-1/2 (38)
591-7020	3/16 (4.8)	591-8072	3/4 (19)	591-8372	1-1/4 (32)	594-8345*	1-1/2 (38)
591-7030	1/4 (6.4)	591-8073	3/4 (19)	591-8373	1-1/4 (32)	594-8361*	1-1/2 (38)
591-7040	1/4 (6.4)	591-8074	1 (25)	591-8374	1-1/2 (38)	594-8363*	1-1/2 (38)
591-7050	3/8 (9.5)	591-8075	1 (25)	591-8376	1-1/2 (38)	594-8375*	1-1/2 (38)
591-7060	3/8 (9.5)	591-8076	1 (25)	591-8378	1-1/4 (32)	594-8377*	1-1/2 (38)
591-7070	9/16 (14)	591-8077	3/8 (9.5)	591-8379	1-1/4 (32)		
591-7080	9/16 (14)	591-8078	3/4 (19)	591-8380	1-1/4 (32)		
591-7090	3/16 (4.8)	591-8079	3/4 (19)	593-8381	1-1/4 (32)		
591-7100	5/16 (7.9)	591-8080	1 (25)	593-8382	1-1/2 (38)		
591-7110	9/16 (14)	591-8081	1 (25)	593-8383	1-1/2 (38)		
591-7870	3/4 (19)	591-8082	1 (25)	593-8388	3/4 (19)		
591-7871	3/4 (19)	591-8330	5/8 (16)	593-8389	3/4 (19)		

* RL 147 is standard with the product.

**Calibration,
 Continued**

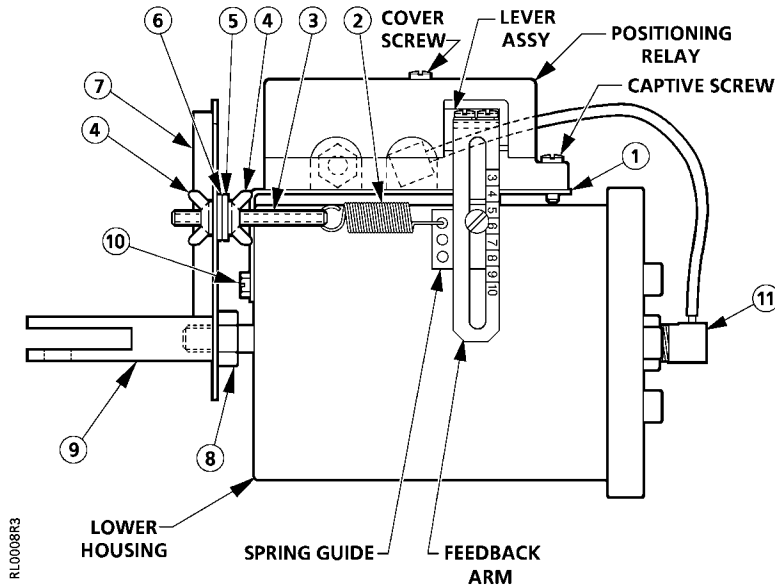

Figure 6. Positioning Relay Mounted on the No. 3 Damper Actuator.

Table 6. Mounting Kit 147-104 for the No. 3 Damper Actuator.

Item	Description	Qty.
1	Mounting Bracket	1
2	Feedback Spring (for 2-3/8" stroke)	1
3	Adjusting Screw 1-3/4" (44 mm) long	1
4	Wing Nut	2
5	Lock Washer	1
6	Flat Washer	1
7	Spring Arm	1
8	3/8-24 Hex Nut	1
9	Clevis	1
10	No. 10-16 1/2" (13 mm) Slotted Hex Screw	2
11	90° Elbow Connector	1

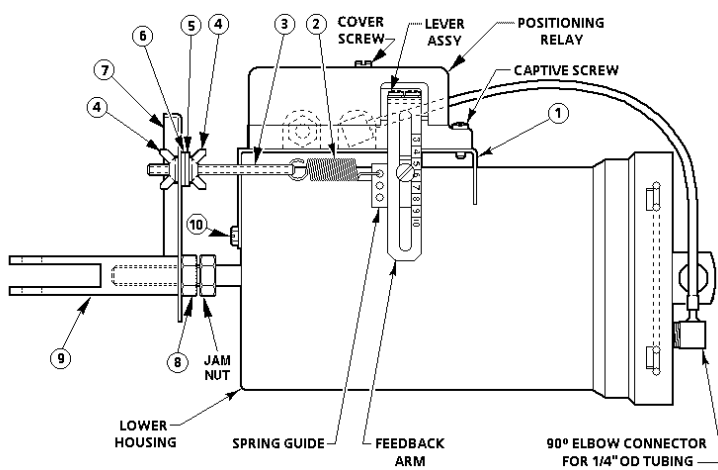

Figure 7. Positioning Relay Mounted on the No. 4 Damper Actuator.

Table 7. Mounting Kit 147-314 for the No. 4 Damper Actuator

Item	Description	Qty.
1	Mounting Bracket	1
2	Feedback Spring	1
3	Adjusting Screw 1-3/4" (44 mm) long	1
4	Wing Nut	2
5	Lock Washer	1
6	Flat Washer	1
7	Spring Arm	1
8	3/8-24 Hex Nut	2
9	Clevis	1
10	No. 10-16 1/2" (13 mm) Slotted Hex Screw	1

Calibration, Continued

Table 8. Spring Selection for Adjustable Stroke of the No. 6 Damper Actuator.

Actuator Stroke	Feedback Spring			Adjusting Screw
	Color	Nominal	Max	
3-1/4 to 4 (82 to 102)	Blue	4 (102)	4-1/4 (108)	4-1/2 (114) long
2-29/32 to 3-1/4 (74 to 82)	Cadmium	3 (76)	3-1/4 (82)	1-3/4 (44) long

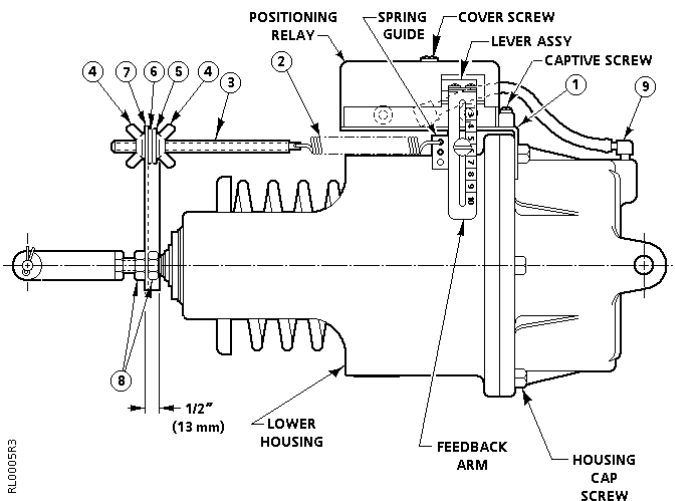

Figure 8. Positioning Relay Mounted on the No. 6 Damper Actuator.

Table 9. Mounting Kit 147-276 for the No. 6 Damper Actuator.

Item	Description	Qty.
1	Mounting Bracket	1
2	Feedback Spring 4" (102 mm) stroke (blue)	1
	Feedback Spring 3" (76 mm) stroke (Cad.)	1
3	Adjusting Screw 4-1/2" (114 mm) long	1
	Adjusting Screw 1-3/4" (44 mm) long	1
4	Wing Nut	2
5	Lock Washer	1
6	Flat Washer	1
7	Spring Arm	1
8	3/8-24 Hex Nut	2
9	90° Elbow Connector	1

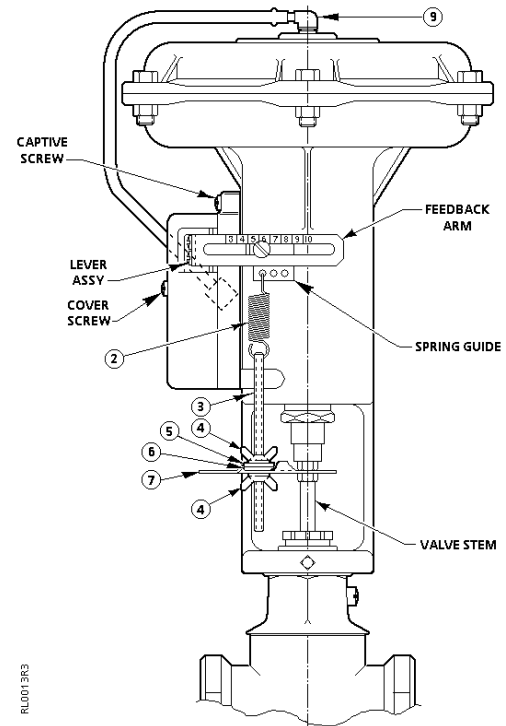

Figure 9. Positioning Relay Mounted on a VP 591 8-inch Valve Actuator.

Table 10. Mounting Kit 147-333 for the VP 591 8-inch Valve Actuator.

Item	Description	Qty.
2	Feedback Spring-Small Cadmium Plate	2
	Feedback Spring-Small Red	1
	Feedback Spring-Large Green	1
	Feedback Spring-Small Green	2
3	Adjusting Screw 4-inch (102 mm) long	1
4	Wing Nut	2
5	Lock Washer	1
6	Flat Washer	1
7	Spring Arm	2
9	90° Elbow Connector	1

**Calibration,
 Continued**

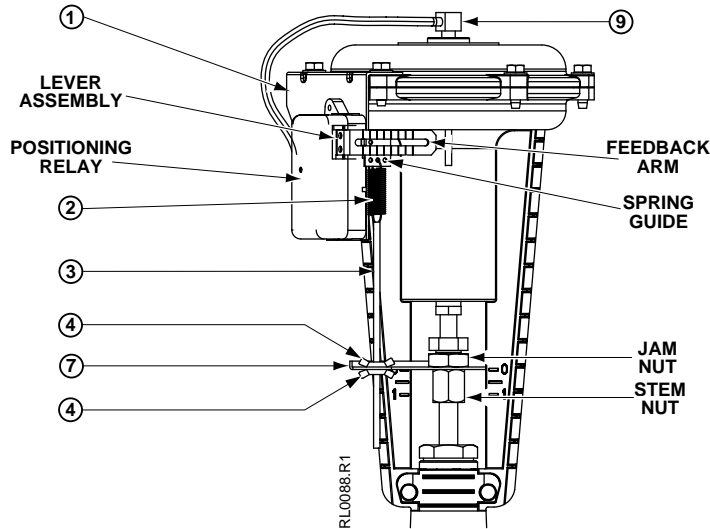

Figure 10. Positioning Relay Mounted on a Flowrite 599 Series 8-inch Valve Actuator.

Table 11. Kit 599-00426 for the Flowrite Series 599 8-inch Valve Actuator.

Item	Description	Qty.
	RL 147 Positioning Relay	1
1	Mounting Bracket	1
2	Feedback Spring	1
3	Adjusting Screw	1
4	Wing Nut	2
7	Spring Arm	1
9	90° Elbow Connector	1

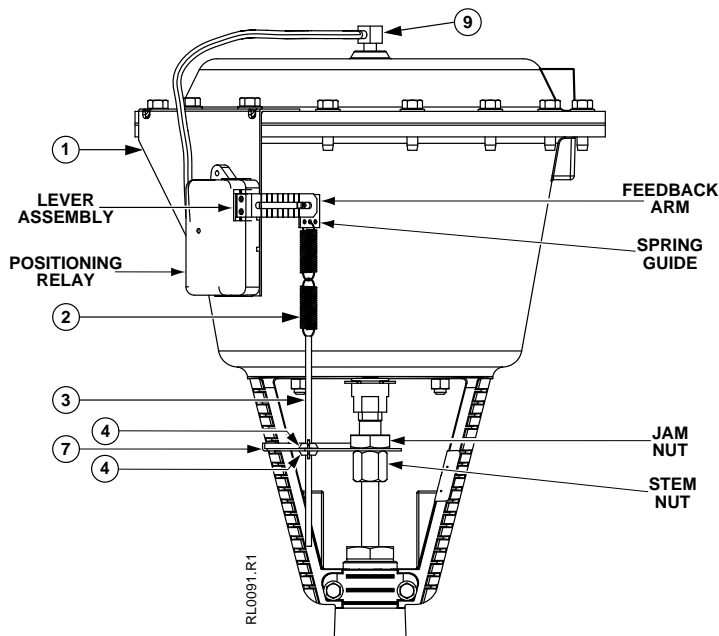

Figure 11. Positioning Relay Mounted on a Flowrite Series 599 12-inch Valve Actuator.

Table 12. Kit 599-00423 for the Flowrite Series 599 12-inch Valve Actuator.

Item	Description	Qty.
	RL 147 Positioning Relay	1
1	Mounting Bracket	1
2	Feedback Spring	2
3	Adjusting Screw	1
4	Wing Nut	2
7	Spring Arm	1
9	90° Elbow Connector	1

**Calibration,
 Continued**

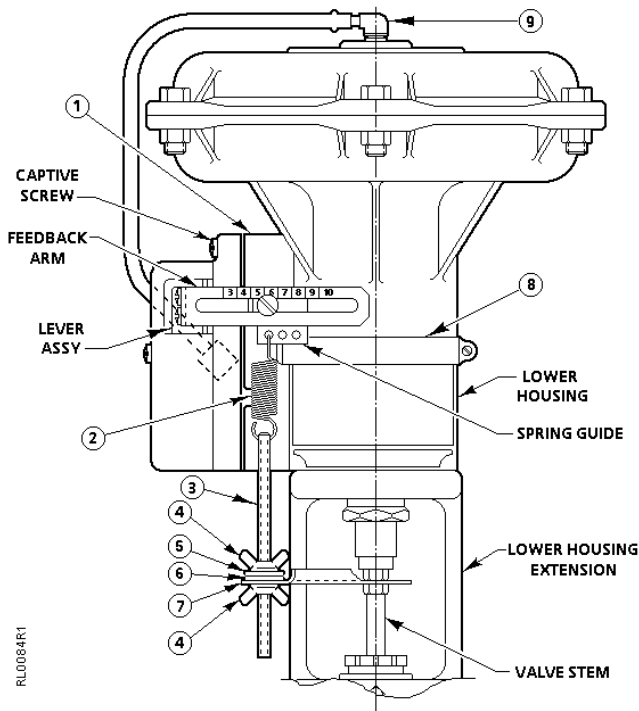

Figure 12. Positioning Relay Mounted on the Flowrite 8-inch Actuator (Models 1 and 2) and Super Flowrite.

Table 13. Mounting Kit 147-277* for Flowrite 8-inch Valve Actuator Models 1 and 2.

Item	Description	Qty.
1	Mounting Bracket	1
2	Feedback Spring, Small Cadmium Plate	2
	Feedback Spring, Small Red	1
	Feedback Spring, Large Green	1
	Feedback Spring, Small Green	2
3	Adjusting Screw, 4-1/2" (114 mm)	1
4	Wing Nut	2
5	Lock Washer	1
6	Flat Washer	1
7	Spring Arm	1
8	Sure-tite Clamp	1
9	90° Elbow Connector	1

*Also order spring arm No. 147-307 for use with VF 591 5-inch and 6-inch balanced valves.

Table 14. Mounting Kit 147-279 for Super Flowrite and 12-inch Flowrite Before March 1978. See Figure 12.

Item	Description	Quantity
1	Mounting Bracket	1
2	Feedback Spring-Small Cad. Plate	2
	Feedback Spring-Small Red	2
	Feedback Spring-Large Green	1
3	Adjusting Screw-4-1/2" (114 mm) long	1
4	Wing Nut	2
5	Lock Washer	1
6	Flat Washer	1
7	Spring Arm	1
8	Sure-Tite Clamp	1
9	90° Elbow Connector	1

Calibration, Continued

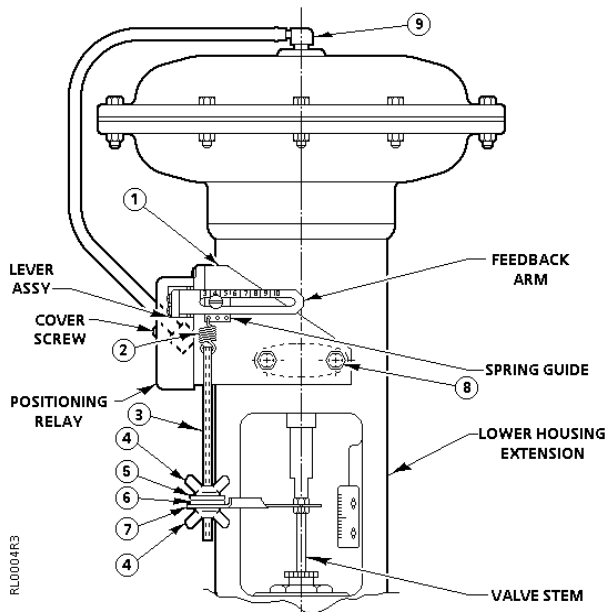

Figure 13. Positioning Relay Mounted on a VP 591/3 Flowrite Valve Actuator.

Table 15. Mounting Kit 147-311 for the VP 591/3 Flowrite Valve Actuator.

Item	Description	Qty.
1	Mounting Bracket	1
2	Feedback Spring, Small Cadmium Plate	2
	Feedback Spring, Small Red	2
	Feedback Spring, Large Green	2
3	Adjusting Screw, 6-1/2" (165 mm)	1
4	Wing Nut	2
5	Lock Washer	1
6	Flat Washer	1
7	Spring Arm	1
8	5/16-18 x 1/2 long Cap Screw	2
9	90° Elbow Connector	1

Dimensions

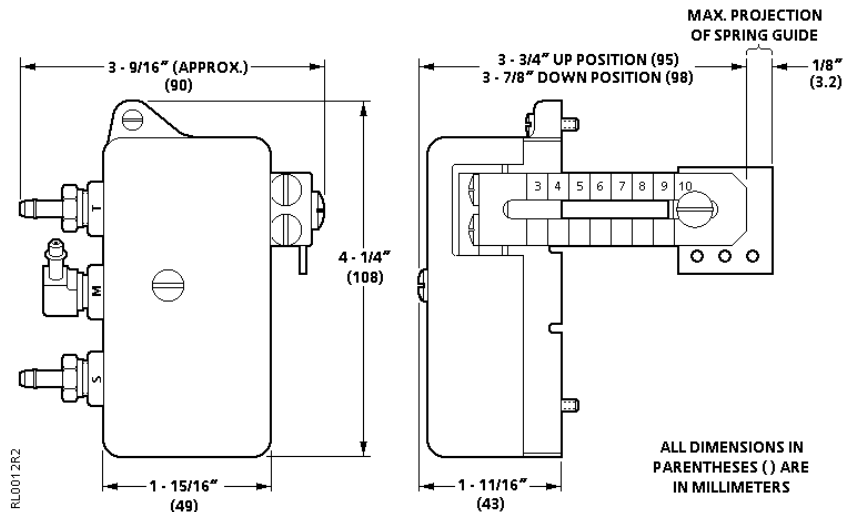

Figure 14. Dimensions in Inches (Millimeters).

Information in this publication is based on current specifications. The company reserves the right to make changes in specifications and models as design improvements are introduced. Powers is a registered trademark of Siemens Building Technologies, Inc. Other product or company names mentioned herein may be the trademarks of their respective owners. © 2005 Siemens Building Technologies, Inc.